

CARTEK **MOTORSPORT ELECTRONICS**

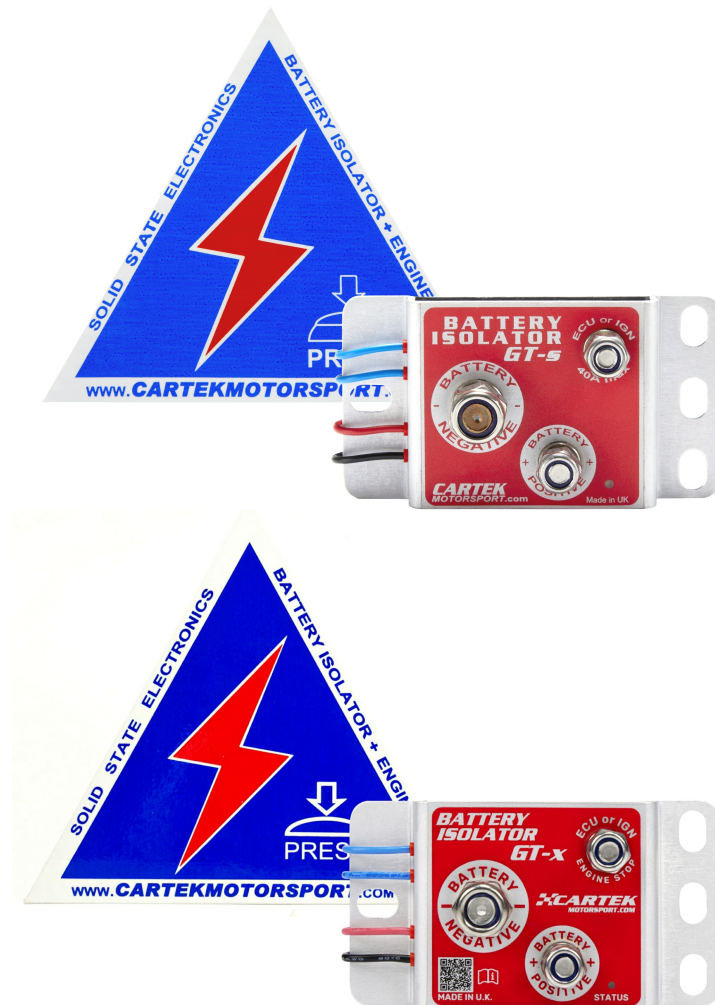

BATTERY ISOLATOR *GT-S* & *GT-X*

USER MANUAL

REV 1.0

**MOTORSPORT IS DANGEROUS.
THIS PRODUCT IS DESIGNED FOR MOTORSPORT USE ONLY AND SHOULD NOT
BE USED ON ROAD/STREET VEHICLES OR ON PUBLIC HIGHWAYS.
NO WARRANTY IS MADE OR IMPLIED REGARDING ANY CARTEK PRODUCTS TO
PROTECT USERS FROM INJURY OR DEATH.
USER ASSUMES ALL RISKS.**

CONTENTS

APPLICATION.....	3
TECHNICAL SPECIFICATION.....	3
DIMENSIONS.....	3
WIRING SPECIFICATION.....	3
PRODUCT DESCRIPTION.....	4
USER OPERATION.....	4
SAFETY PRECAUTIONS	4
INSTALLATION.....	5
MOUNTING.....	5
SWITCH CONNECTIONS.....	5
ENGINE STOP CONNECTION.....	6
BATTERY CONNECTIONS.....	7
STATUS LED.....	8
FAULT DIAGNOSIS.....	9
POWER SAVE.....	9
TROUBLESHOOTING.....	10

APPLICATION

The CARTEK Battery Isolator GT is designed to be used on a wide variety of race and rally cars - up to mildly tuned V8 engines.

The CARTEK Battery Isolator GT-s model is the first generation Battery Isolator (2010-2025).

The CARTEK Battery Isolator GT-x model is the second generation Battery Isolator (2026+).

Note: Not suitable for Electric or Hybrid vehicles.

TECHNICAL SPECIFICATION

Size:	L = 92mm (3.62in), W = 50mm (1.97in)
Weight:	120g (0.264lbs)
Battery negative terminal:	M8 stud
Operational voltage:	7V - 18V
Current consumption:	50mA ON, 7mA OFF
Battery negative switching current:	600A cranking, 2000A surge
Engine stop output:	40A protected output
Operating temperature:	-10°C - +100°C
Storage temperature:	-40°C - +125°C

DIMENSIONS

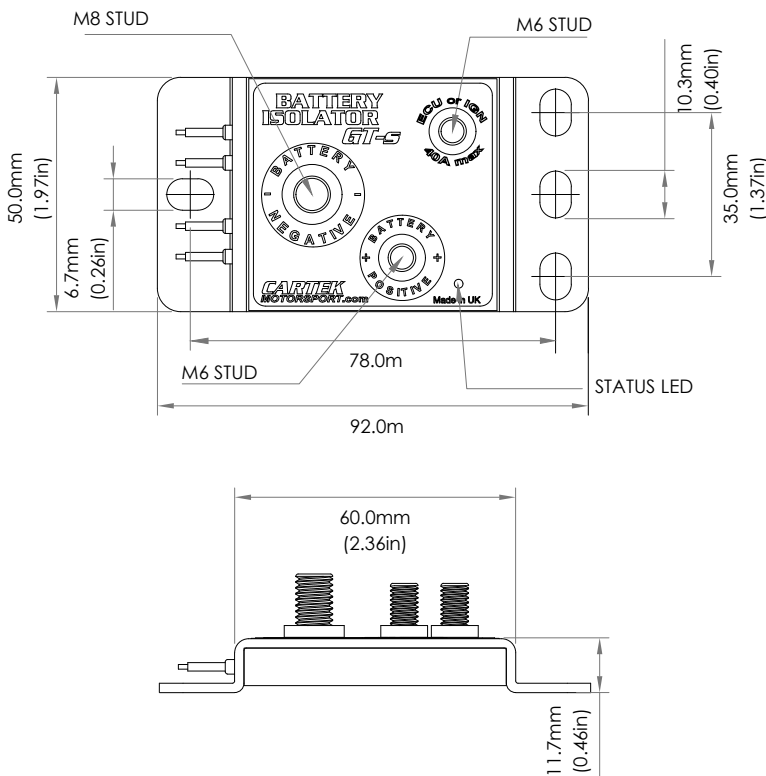

WIRING SPECIFICATION

Wire Name	Colour	Wire Gauge (AWG)	Length (MM)
External Kill Button	Blue	20	20
External Kill Button	Blue	20	20
Internal Switch	Red	20	20
Internal Switch	Black	20	20

DESCRIPTION

All **CARTEK Battery Isolators** are designed to perform two functions in accordance with **FIA** motorsport safety regulations. These are:

- 1) **Stop the Engine from running, 'Kill'.**
- 2) **Disconnect the Battery from ALL electrical systems, 'Isolate'.**

The 'Engine Stop' function is implemented by disconnecting power to the ECU or Ignition circuit - forcing the engine to stop and electrical power generation by the alternator/generator to cease.

The 'Battery Isolation' function is implemented by disconnecting the negative side of the vehicle's battery from chassis/ground, thereby disconnecting the battery from ALL of the car's electrical systems.

When activated, the Engine Stop function occurs a very short period of time before Battery Isolation. Alternator load dump protection is also built in so no additional components are needed.

USER OPERATION

All **CARTEK Battery Isolators** are operated using two switches:

A dashboard mounted 'Internal Switch' allows the driver to turn the Battery Isolator ON and OFF.

An 'External Switch' is for operation by safety personnel in an emergency situation.

The Internal Switch can be used to turn the Battery Isolator ON and OFF, however the External Switch can only turn the Battery Isolator OFF. This is in accordance with **Motorsport UK** safety regulations.

All **CARTEK Battery Isolators** also shut down automatically if a fault is detected such as short-circuit, over-current, over-temperature or broken cable connections. If this happens then the LED on the Battery Isolator unit, and the **CARTEK Internal Switch**, will display a flash pattern to indicate the cause of the fault. See chapter on LED Status.

SAFETY PRECAUTIONS

- Please read through this user guide thoroughly before installing on your race car. If not installed correctly then damage may occur to the Battery Isolator.
- The Battery Isolator **MUST** be fully connected before starting the engine. If the 'Engine Stop' (IGN/ECU) terminal is not properly connected when the engine is running then damage to the Battery Isolator may occur.
- The Battery Isolator must be removed if any electric welding is being carried out on the car.
- When using a Battery Charger, or an external starter/booster battery, then it is important to connect both cables directly to the car battery. **DO NOT CONNECT THE NEGATIVE CABLE OF THE CHARGER, OR EXTERNAL BATTERY, TO THE CHASSIS. THIS MAY CAUSE DAMAGE TO THE BATTERY ISOLATOR.**

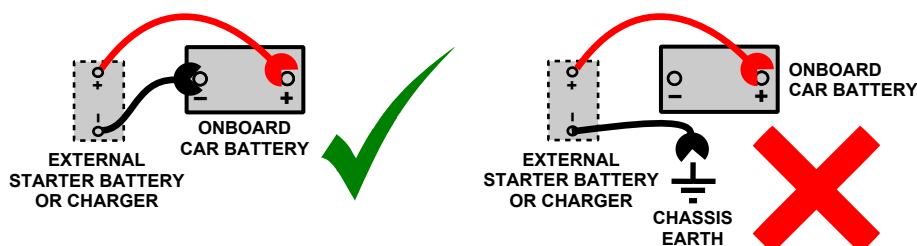

INSTALLATION

To install the Battery Isolator please follow the steps below. These steps must be carried out correctly and in the specified order else the Battery Isolator may not function correctly:

- 1) Mount Battery Isolator to the chassis close to the battery.
- 2) Connect the Internal and External Switches.
- 3) Make the Engine Stop connection.
- 4) Make the connection to Battery Positive.
- 5) Make the connection to Battery Negative.

MOUNTING

The Battery Isolator should be mounted directly to the vehicle's metal chassis and close to the vehicle's battery, but away from any high temperature sources. The Battery Isolator should be mounted securely with two, unpainted screws/bolts to provide good electrical contact with the chassis.. (See Diagram 1.0)

If mounting directly to a metal chassis is not possible then an 'earth' cable can be used to connect the Battery Isolator to a suitable point on the chassis or engine block. (See Diagram 1.1)

NOTE: If the Battery Isolator does not have good electrical connection to the car's chassis then the other electrical systems on the car may not function correctly.

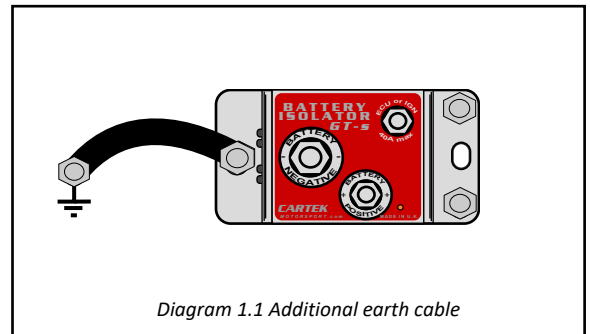
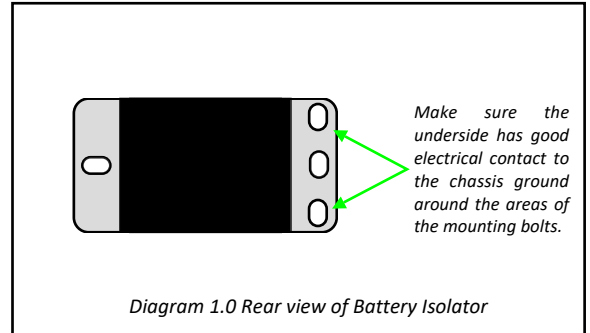

SWITCH CONNECTIONS

The Battery Isolator can be controlled by multiple switches however a typical installation will use 1x Internal ON/OFF switch and 1x External 'KILL' switch.

The Internal Switch must be of a latching type, either toggle or pushbutton, such that the ON position makes the circuit while the OFF position breaks the circuit. When using the **CARTEK Internal Switch (CK-LT-01)** then you must make sure that the Red and Black wires are connected correctly as it is a polarised switch (i.e. **Red-to-Red, Black-to-Black**).

NOTE: Do not apply any voltage to the CARTEK Internal Switch before installing. It is fitted with a low voltage LED and testing it can easily cause permanent damage to the switch.

The External 'KILL' Switch should be momentary, normally-closed (NC), type and connected between the two Blue wires. If required, multiple 'KILL' switches can be incorporated by connecting in series. If no external switch is required then the external circuit needs to be complete by permanently connecting the two Blue wires together. (See Diagrams 1.2 & 1.3)

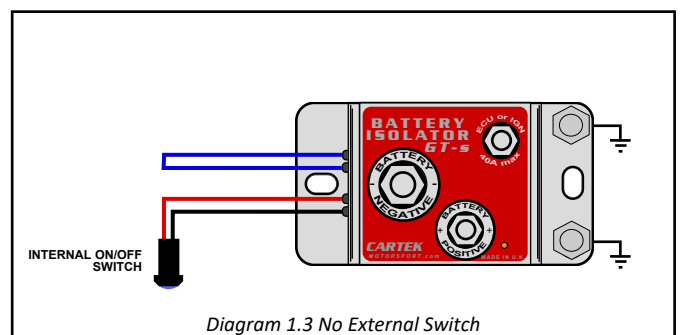
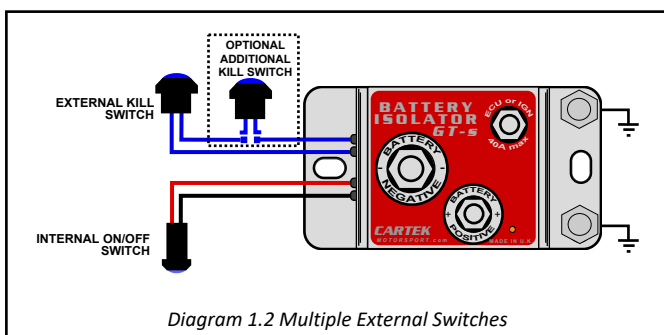

ENGINE STOP CONNECTION

For all cars equipped with alternators the Engine Stop function must be fully implemented. This is because when the engine is running the alternator becomes the main source of electrical power therefore disconnecting the battery will not stop the engine from running.

NOTE: If the Engine Stop feature is not fully functioning then the engine may continue to run when the Battery Isolator has been switched off. This scenario can cause damage to the components inside the Battery Isolator.

There are 3 methods the Engine Stop function can be implemented:

Method 1: Connect the Engine Stop (IGN/ECU) terminal to a Master/Ignition input of a motorsport Power Distribution Module (PDM) or ECU. The ECU/PDM input must be configured as follows:

Engine Run (ON) = 12V (Battery voltage)

Engine Stop (OFF) = 0V (Ground)

Thin, low current cable can be used, e.g. 20-22AWG.

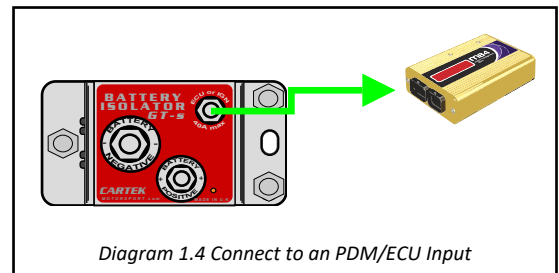

Method 2: Use the Engine Stop (IGN/ECU) terminal to supply +12V power directly to Ignition Switch, Ignition Coil(s) or Fuel Injectors.

Note: The Engine Stop terminal is fully protected. If the output current exceeds 40 Amps then the Battery Isolator will safely shut down.

Cable used here should be suited to the current drawn by the load, e.g. if an Ignition Switch draws 30 Amps then cable should be 10 AWG. If Ignition Coils draw 10 Amps then cable can be 16-18 AWG.

Method 3: Use the Engine Stop (IGN/ECU) terminal to activate a Main Engine Relay (e.g Ignition Relay/Fuel Pump Relay).

Cable used here can be 20-22AWG.
(See Diagram 1.6)

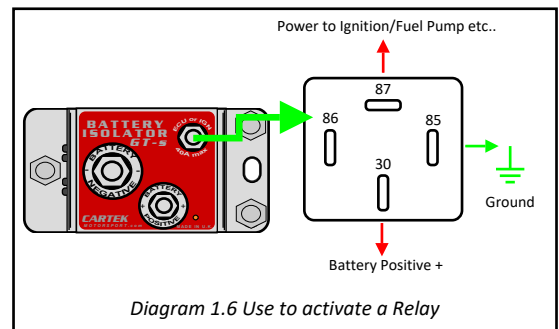
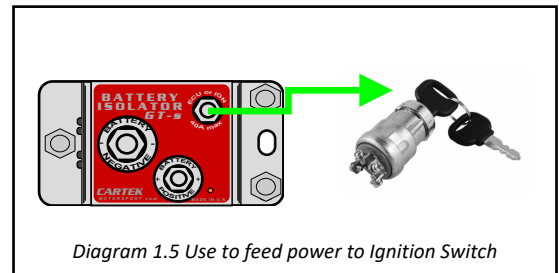

Here is a method to help locate a suitable location for the Engine Stop connection:

- Start the engine.
- Locate fuse or relay for Engine, ECU or Ignition system.
- Remove fuse or relay while engine is running. If this causes engine to immediately stop then this is a possible area for installation of the Engine Stop wire.

Note: The Engine Stop (IGN/ECU) terminal should not be used to power a fuse box nor an Alternator Exciter wire.

Note: For historic/classic cars, if the alternator has an old style 'Battery Charging' warning bulb (not LED) which is connected to the Ignition Switch then a diode must be placed in series e.g. 1N5819.

BATTERY CONNECTIONS

1. Make the **Battery Positive** connection (M6 terminal). This connection should be made using cable of 5-40 Amp capacity depending on the current draw of the Engine Stop output. This must be a permanent connection directly to Battery Positive and not switched power from an Ignition Switch. **M6 Stud maximum tightening torque : 9Nm**
2. Make the **Battery Negative** connection (M8 terminal). This connection should be made using cable of 100-200 Amp capacity and by keeping as short as possible will offer maximum weight saving of the complete installation. No other cable should be attached to Battery Negative (other than a cable to charge/boost the Battery). **M8 Stud maximum tightening torque : 11Nm**

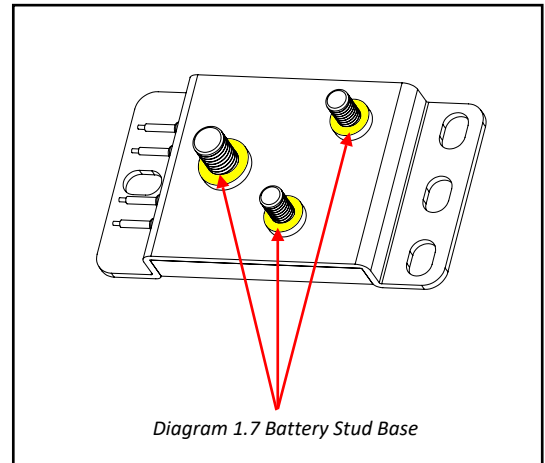

Diagram 1.7 Battery Stud Base

The cable ring terminals should sit flush against the M8 + M6 Stud base as shown in Diagram 1.7. No washer should be fitted between the ring terminal and the M8/M6 stud Base. Also make sure that the cable ring terminal does not make contact with the Battery Isolator label as this can penetrate overtime and cause a short circuit.

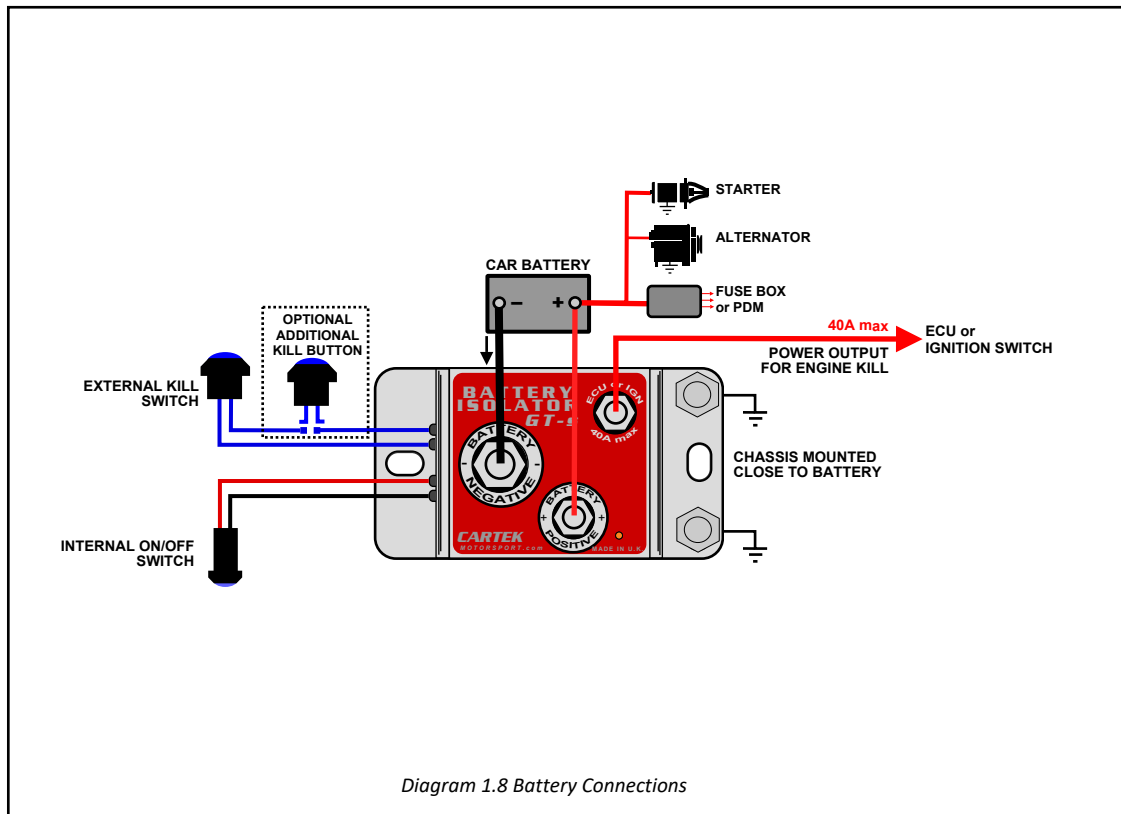

Diagram 1.8 Battery Connections

STATUS LED

Once fully installed, the Battery Isolator is switched ON by activating the internal ON-OFF switch. On activation the Battery Isolator performs a system check before electrical power is switched ON. If any fault is detected then the Battery Isolator will remain in the OFF state and display a fault code via the LED on the Battery Isolator unit in a sequence of flashes:

BATTERY ISOLATOR GT-S

Battery Isolator Status	LED Flash Code
First time battery connection, power-up/reset.	2x Flashes (Red)
Battery Isolator is OFF (standby).	Faint flickering (continuous) - only noticeable on Battery Isolator. (Red)
Battery Isolator is ON.	Static (Red)
External Switch pressed or External Switch cable(s) broken or disconnected.	1x Flash (Red), pause, 1x flash, pause (continuous).
Maximum Temperature exceeded.	2x Flashes (Red), pause, 2x flashes, pause (continuous).
Maximum current in Engine Stop circuit exceeded (>40A)	4x Flashes (Red), pause, 4x flashes, pause.... (continuous).
Maximum current in NEGATIVE circuit exceeded/ Battery Isolator error.	8x Flashes (Red), pause, 8x flashes, pause.... (continuous).

BATTERY ISOLATOR GT-X

Battery Isolator Status	LED Flash Code
First time battery connection, power-up/reset.	5x Flashes (Blue)
Battery Isolator is OFF (standby).	Slow Flash (Blue)
Battery Isolator is ON.	Static (Green)
Maximum Temperature exceeded.	2x Flashes (Red), pause, 2x flashes, pause (continuous).
External Switch pressed or External Switch cable(s) broken or disconnected.	3x Flashes (Red), pause, 3x flashes, pause.... (continuous).
Maximum current in Engine Stop circuit exceeded (>40A)	4x Flashes (Red), pause, 4x flashes, pause.... (continuous).
Low Battery Voltage error (<7V)	5x Flashes (Red), pause, 5x flashes, pause.... (continuous).
High Battery Voltage error (>18V)	6x Flashes (Red), pause, 6x flashes, pause.... (continuous).
Battery Short-circuit detected.	7x Flashes (Red), pause, 7x flashes, pause.... (continuous).
Maximum Battery current exceeded.	8x Flashes (Red), pause, 8x flashes, pause.... (continuous).
Engine Kill function not operating.	9x Flashes (Red), pause, 9x flashes, pause.... (continuous).
Fault with installation or internal fault detected.	10x Flashes (Red), pause, 10x flashes, pause.... (continuous).

Once the fault is remedied the Battery Isolator can be reset by switching OFF the internal switch then switching ON again. The Battery Isolator will also be fully reset by disconnecting from the vehicle battery and reconnecting.

FAULT DIAGNOSIS

The Battery Isolator will safely shut down if any of the following situations occur:

Maximum temperature exceeded.

This may occur after very prolonged engine cranking or if the Battery Isolator is mounted close to a source of heat e.g. engine, coolant pipes, exhaust, radiator fan, etc.

External Switch pressed or External Switch circuit broken.

(This is the most common fault if the car shuts down unexpectedly while on track). If the External Switch has not been operated then check the wiring between the Battery Isolator and the External Switch. Here are two helpful hints to identify this fault:

- If the engine can be started then physically shake all wiring associated with the Battery Isolator installation. If the engine stops unexpectedly while doing this then this may identify the location of a loose electrical connection.
- If the engine cannot be started then temporarily join the two Blue wires together, close to the Battery Isolator unit, to bypass the external kill button and associated wiring. If the engine can now be started then this will confirm a fault in the External Switch wiring.
- If the engine cannot be started then temporarily join the Red and Black wires together, close to the Battery Isolator unit, to bypass the internal ON/OFF switch and associated wiring. If the engine can now be started then this will confirm a fault in the Internal ON/OFF Switch wiring.

Maximum current in Engine Stop circuit exceeded.

The maximum current this Engine Stop can output is 40 Amp continuous and 60 Amp surge.

Low Voltage error.

The Battery Voltage has dropped under 7V which is lower than the minimum operating voltage of the Battery Isolator. Check the Battery is charged and maintaining voltage. Check the battery negative connection cable is of suitable size for starter motor cranking and its connections are tight.

High Voltage error.

The Battery Voltage has exceeded 18V which is higher than the maximum operating voltage of the Battery Isolator. Check alternator is functioning correctly.

Short-circuit detected.

Check for a short circuit from Battery Positive to chassis such as loose or damaged cables, faulty alternator or starter motor.

Maximum Battery current exceeded.

This fault is likely to only occur when cranking the engine. This is an indication that the current consumption of the starter motor has exceeded the maximum of the Battery Isolator.

Engine Stop function not operating.

Battery Isolator is unable to stop the engine. Make sure the Engine Stop terminal (IGN/ECU) is connected to an appropriate part of the car's electrical system such as Ignition Switch, ECU, Engine Relay or Ignition Coil(s).

Battery Isolator Error.

The Battery Isolator is unable to operate correctly. Possible installation error or internal fault/damage.

POWER SAVE

If the battery voltage drops below 11 Volts and remains low for 90 minutes then the Battery Isolator will turn itself OFF (if left switched ON) to reduce current draw and help protect the battery.

NOTE: This will not occur when the engine is running, nor when the car is being driven, as long as the alternator maintains a battery voltage greater than 11 Volts.

TROUBLESHOOTING

ISSUE: The Battery Isolator will not turn ON

If the Battery Isolator will not turn ON and the Status LED remains in standby, then this may indicate a fault with the Internal ON/OFF switch or connection to this switch. If you are using the Cartek Internal Switch (with integrated LED) then the Red and Black wires must be connected Red-Red, Black-Black to the corresponding wires of the Battery Isolator otherwise the switch will not function.

IMPORTANT NOTE: Do not test for voltage/resistance on the Cartek Internal ON/OFF Switch as doing so can damage the integrated LED and make the switch inoperative. All CARTEK Internal Switches are fully tested at the factory before shipping.

Confirmation of this fault can be determined by temporarily joining the Red and Black wires together close to the Battery Isolator unit thereby bypassing the Internal ON/OFF switch and associated wiring/connections. If the Battery Isolator now turns ON then this will indicate a fault does exist with the Internal ON/OFF switch or associated wiring. If the Battery Isolator is still unable to switch on then check connections to Battery Positive, Battery Negative and chassis mounting.

ISSUE: The Battery Isolator switches OFF and the car cuts out when going around corners or over bumps

This will be caused by a loose electrical connection, most commonly with the wires or connections associated with the External 'Kill' Switch. The External Switch circuit is an electrical loop and any break, even temporary, will cause the Battery Isolator to shut down. Make sure all connections are properly crimped or soldered and fully insulated. Here are two helpful hints to identify this type of fault:

- If the engine can be started then physically shake all wiring associated with the Battery Isolator installation. If the engine stops unexpectedly while doing this then this may identify the location of a loose electrical connection.
- If the engine cannot be started then temporarily join the two Blue wires together, close to the Battery Isolator unit. Now join the Black and Red wires together thereby bypassing both External and Internal Switches. If the engine can now be started then this will confirm a fault in the area of the Switches.

ISSUE: The Engine will not stop running when the Battery Isolator is switched OFF

- Make sure there is only one cable attached to the negative terminal of the battery and that this cable connects to the Battery Isolator only and nowhere else. There must be no cable connecting the negative terminal of the battery to the chassis.
- Check the 'Engine Stop' cable and follow this to where it has been connected on the car. (**The only time this 'Engine Stop' cable does not need to be connected is if the car does not have an alternator fitted.**) The electrical system/device to which it is connected (e.g. Ignition Switch, ECU, Coils) should be powered by this 'Engine Stop' connection from the Battery Isolator only. If the electrical system/device has another supply of power then this will cause the engine to keep running.
- Measure the voltage on the Engine Stop cable when the Battery Isolator is switched OFF and when it is switched ON. **NOTE: Make sure the Negative (Black) probe of the voltmeter is connected to the chassis and not Battery Negative as this will give a false measurement.**

- Battery Isolator **ON** = +12V (Battery Voltage)
- Battery Isolator **OFF** = 0V (Grounded)

If these voltages are not detected then disconnect this Battery Isolator Engine Stop cable from the car's electrical system and measure the voltages again. If the voltages are now correct, then this will indicate that the Engine Stop connection has been wired to an incorrect part of the car.

- If using the Engine Stop cable to act as an Ignition/Master input signal on a PDM or ECU then make sure the input on the PDM/ECU has been configured to respond to the voltages described above.

ISSUE: There is Voltage when the Battery Isolator is switched OFF

When making any voltage measurements on a car that is fitted with a Cartek Battery Isolator, it is important that the negative (Black) lead of the voltmeter is always attached to the chassis and not to the negative side of the car battery.

When a Cartek Battery is in the OFF/Standby state, and has disconnected the negative side of the car battery from chassis/ground, then a voltage can be detected between chassis and battery negative. Although a voltage here can be detected and measured it has no power. It cannot create a spark nor power anything electrical, not even an LED. It is what is known as a 'floating voltage' This is normal and safe.